



RTC-ELECTRO-M
RUSSIAN TECHNICAL COMPANY

CATALOGUE

Solid insulated bus bar type TPL For safety critical applications



Cast-resin bus bar type TKL

Fit & Forget solutions for lowest lifecycle costs

CONTENTS:

General information about the solid cast resin insulated bus bars	3
Field of application	3
Range of Electrical Application	3

SOLID INSULATED BUS BAR TYPE TPL

Intended use	4
Features of TPL	4
Technical specifications	4
Manufacture of solid insulated bus bar type TPL	4
TPL connecting sleeves	5
Solid insulated bus bar type TPL fixing system	6
TPL fireproof wall penetrations	7
Earthing of the bus bar	7
Connection to equipment	8
Additional equipment and accessories	8
Type tests	9
Additional equipment and accessories	9
The standard set of equipment	9

CAST-RESIN BUS BAR TYPE TKL





Intended use	10
Operation conditions	10
Features of TKL	10
Technical specifications	10
Production lines of the bus bar	10
Connection methods of elements	12
Electric connection methods	12
Additional equipment and accessories	12
Type tests	13
Installation methods	13
The standard set of equipment	13

Quality assurance and certification of cast-resin bus bar type TKL and solid insulated bus bar type TPL	14
Fire safety	14
Our core business	14
Questionnaire	15

GENERAL INFORMATION

CAST-RESIN BUS BAR TYPE TKL AND SOLID INSULATED BUS BAR TYPE TPL

FIELD OF APPLICATION:

	POWER PLANTS Generator — Generator circuit-breaker — Transformer Switchgear — Switchgear Auxiliary circuits
	SUBSTATIONS Transformer — Current limiting reactor — Switchgear Switchgear — switchgear
	INDUSTRIAL MANUFACTURING Petrochemical, Chemical, Metallurgical, Pulp-and-paper, etc. For low & medium voltage electrical distribution
	CIVIL ENGINEERING OBJECTS High-rise residential and office buildings, Hospitals, Hotels, Casinos, Retail and entertainment centers, etc.
	OFFSHORE both oil & gas and wind park substations Transformer — Switchgear Switchgear — Switchgear Auxiliary transformer & other equipment

RANGE OF ELECTRICAL APPLICATION

	TPL bus bars	TKL bus bars
Type of insulation	Epoxy Resin Impregnated Paper	Cast resin
Nominal voltage AC, kV	Up to 36	Up to 24
Nominal current AC, A	Up to 12 000	Up to 12 000
Nominal voltage DC, kV	Up to 60	Up to 33
Nominal current DC, A	Up to 14 000	Up to 18 000
Operating ambient temperature, °C	From -60° to +55 °C	From -60° to +55 °C
Degree of protection	Up to IP68 inclusive	
High chemical resistance	Yes	Yes

SOLID INSULATED BUS BAR TYPE TPL

INTENDED USE

The solid insulated bus bar type TPL is ideal for medium & low voltage safety critical projects. TPL is both electrically and geometrically made to measure according to project specifications. Up to 36 kV & 6 500 A per single phase is possible. For shorter generator connections, where space is very limited, it is possible to provide up to 36 kV & 12 000 A. Here we use 2 X bus bars per phase.

FEATURES of TPL

- Suitable for outdoor & indoor applications
- Ambient temperature from -60° to +55 °C
- Very high degree of protection up to IP68, suitable for marine & wet environments
- High resistance to ultraviolet, chemicals and aggressive environments
- Touch safe
- Maintenance free
- High degree of fire withstand
- Small overall dimensions and bending radius
- No phase to phase short circuit possible
- Partial discharge free according to IEC 60137
- Modular distribution kit, simply bolted together with no special tools required
- Natural (air) cooling,
- Very low power losses (I^2R)
- Lowest lifecycle costs for end clients

4

TECHNICAL SPECIFICATIONS

Low voltage systems:

	AC	DC
Nominal voltage	Up to 1,2 kV	Up to 2 kV
Nominal current	Up to 12 000 A	Up to 14 000 A

Medium voltage systems:

	AC	DC
Nominal voltage	Up to 36 kV	Up to 60 kV
Nominal current	Up to 12 000 A	Up to 14 000 A

MANUFACTURE OF SOLID INSULATED BUS BAR TYPE TPL

VOID FREE, PARTIAL DISCHARGE FREE ACCORDING TO IEC 60137

TPL can be manufactured in lengths up to 10 meters long. The product is cured in an autoclave under vacuum & heat. The dimensions of the autoclave are 10 m × 2 m × 2 m. Almost any geometric shape is possible, below are some examples.

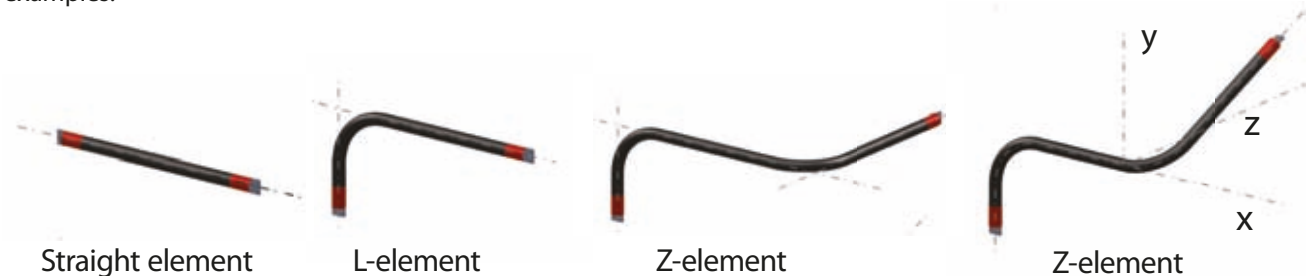

Pre manufacture all raw materials quality checked

- Measurement of specific resistance conductors & capacitors
- Verification of purity & tearing strength test for insulating paper
- Viscosity, viscosity rise with temperature as parameter, gelation time impregnating resin

THE SOLID INSULATED BUS BAR TYPE TPL

Curing in Autoclave is computer monitored

Drying process
Impregnation process
Insulation curing and hardening
Controlled cooling

Electrical Testing of Bus bars & connecting sleeves

After manufacture each insulated component is high voltage tested in our test laboratory
Power frequency test
Partial discharge test according to IEC 60137
Capacitance measurement
Tan delta measurement

Internal Quality Checks

Complete project design
Marking, preservation, packaging and completeness checks

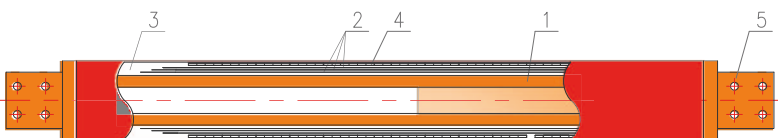

Figure 1.
The bus bar element's construction drawing

1. Conductor (Al, Cu)
2. Capacitive grading
3. Epoxy-impregnated paper wrapping
4. Earth layer
5. Flat terminal

The basic conductor tube (1) can be aluminium or copper & either solid or hollow, depending upon amperage. Then the conductor tube is wrapped with crepe paper and layers of semi conducting paper (2) in order to provide the capacitive grading layers. During manufacture under vacuum, epoxy is pulled through to ensure a void free partial discharge free composite dielectric (3). The embedded earth layer ensures that the system is touch safe whilst operational (4). To make connections easy between Bus bar — bus bar and bus bar — other equipment, there is a DIN flat terminals (5) at the ends of each element.

For low voltage solid insulated bus bar type TPL solutions up to 1.2 kV there are no capacitive grading layers & no earth layer required.

TPL CONNECTING SLEEVES



Bus bars have capacitive control therefore there is a red grading length on the ends. Separate bus bar elements are connected to each other by use of bus expansion compensators which are flexible copper laminate connections.

These allow for thermal expansion & contraction. They also allow build tolerances of up to ± 50 mm per connection.

The connection is then enclosed by a fully capacitively graded insulated connecting sleeve which has pressure-tight flanges on the both sides.

In order to balance the potential between the current carrying conductor and the internal surface of the connecting sleeve a metal ring with contact spring are provided (3).

Connecting sleeve:

Figure 2. The bus bar elements connection

a) indoor application:

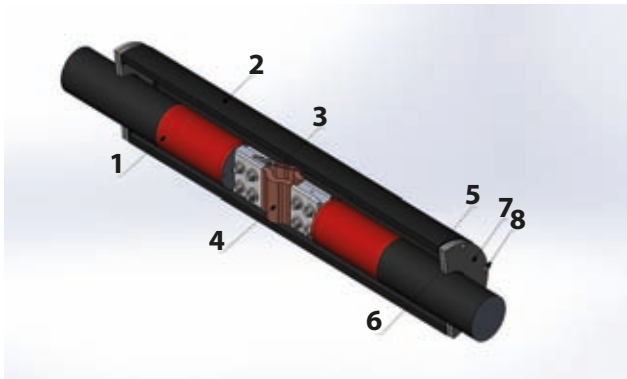

1. Busbar element
2. Connecting sleeve
3. Contact spring
4. Flexible
5. Flat washer

b) outdoor application:

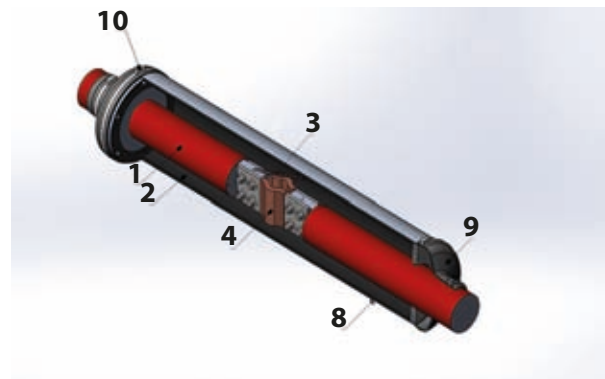

6. Sealing ring
7. Half flange
8. The connecting sleeve's earthing
9. Bellows
10. Clamp

6

SOLID INSULATED BUS BAR TYPE TPL FIXING SYSTEM

We use a special computer program to dimension the fixing system, taking into account short circuit current, natural frequency & weight.

The distance between the mounting places of the bus bar to the walls, ceiling or floor is calculated, prohibited distances are also calculated.

Fixation of the bus bar (Figure 3) to the walls, ceiling or floors is carried out by means of polyamide clamps (1), aluminum x-profiles (2), fixing angles (3) and hardware.

Mounting to a wall allows both horizontal and vertical installation of the bus bar. We can also mount to the floor where the project requires this.

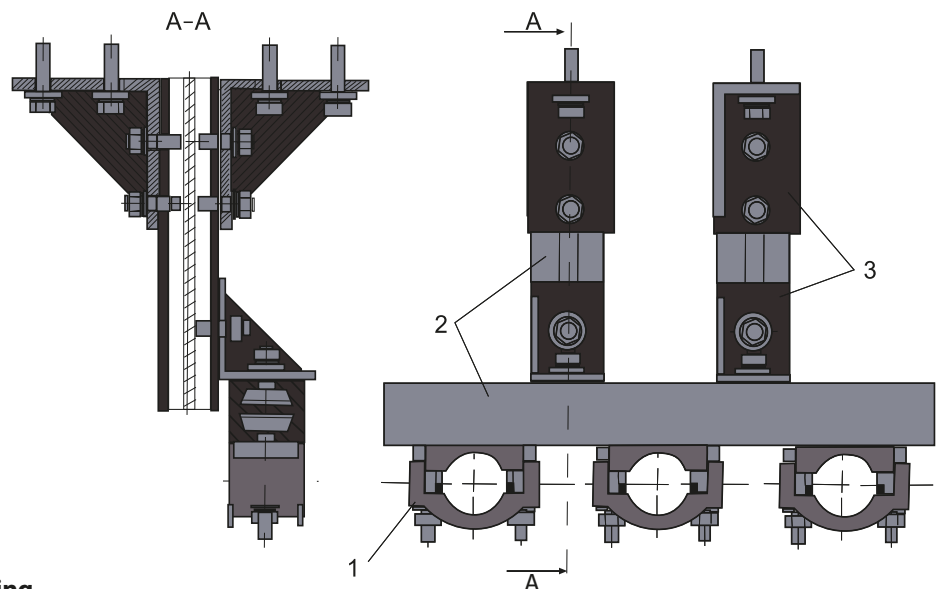

Figure 3.
Elements of the bus bar mounting

THE SOLID INSULATED BUS BAR TYPE TPL

TPL FIREPROOF WALL PENETRATIONS

TPL is compatible with any fireproof penetration which our clients require for their projects. In the example below, the penetrations are filled with a special non combustible material and then closed using metal plates.



EARTHING OF THE BUS BAR

The bus bar equipment is individually earthed as follows, the bus bars, the connecting sleeves and the fixing system. Then this can be connected to the main earth as shown in example photograph below.

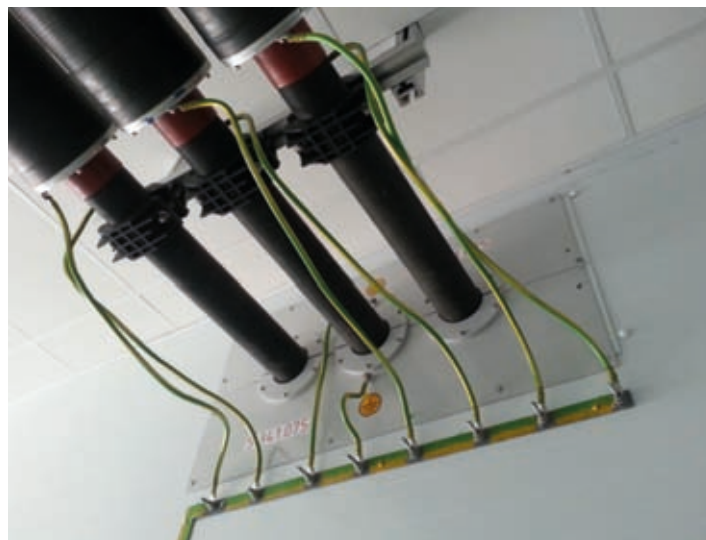

CONNECTION TO EQUIPMENT

According to individual project specifications and requirements, we select the optimal bus bar path to ensure the safest shortest route.

Connections to other equipment can be from the top, the side, or underneath.

Generator & transformer connections are enabled using high flexible copper connections.

Protection boxes/special flanges can be supplied where necessary.



8

ADDITIONAL EQUIPMENT AND ACCESSORIES

Where we connect switchgears using TPL, we can also supply current and voltage transformers, disconnecting switches, overvoltage limiters.

We can also supply bus bar — cable connections & accessories.



TYPE TESTS

In addition to in house routine testing our products have undergone rigorous type testing as follows:

- Heat tests;
- Tests for stability under continuous currents of a short-circuit;
- Tests for resistance to mechanical factors of the environment;
- Tests for mechanical stability;
- Water-proof and dust-proof tests;
- Tests for heat resistance and frost resistance during the operation, transportation and storage;
- Tests of the electric strength of insulation;
- Test for the intensity of partial discharges;
- Seismic stability tests and other tests.

ADDITIONAL EQUIPMENT AND ACCESSORIES

Depending on the specification requirements, TPL bus bar can be completed with an additional electric equipment:

- Current transformers
- Voltage transformers
- Disconnecting switches
- Tap off boxes for the cable connection
- Overvoltage limiters
- Automatic circuit breakers
- Tap-offs for other rated currents

THE STANDARD SET OF EQUIPMENT

TPL modular distribution kit is delivered on site complete with all components/documents required for installation. The delivery package is created according to design documentation and rigorously checked prior to dispatch. The list below shows the main elements.

HARDWARE includes:

- Bus bar elements;
- Connecting sleeves;
- Flexible or high flexible bus expansion compensators for connection of elements to each other and connections of the bus bar to equipment;
- Fixation system, including aluminum x-profiles and a hardware;
- Earthing cable;
- Nuts & bolts;
- Warranty card;
- Test reports.

SOFTWARE includes:

- Packing list;
- The set of assembly factory drawings;
- Installation instruction manual;
- Operation manual;
- Test reports for each element;
- Technical passport.

PACKING

According to the design documentation bus bars & components are packed and fastened into wooden boxes. The bus bar elements are fastened on pallets unwrapped, however, the ends with capacitive grading are protectively wrapped. Separately delivered small size assembly units, details and fasteners are packed into wooden boxes according to the design documentation.

CAST-RESIN BUS BAR TYPE TKL

INTENDED USE

The compact dimensioned cast resin bus bar TKL is intended for connections in AC & DC circuits. For AC circuits the voltage range is up to 24 kV and rated current is up to 12 000 A, frequency can be 50 or 60 Hz. For DC circuits the voltage range is up to 33 kV, rated current up to 18 000 A.

OPERATING CONDITIONS

TKL is intended for operation between ambient temperatures ranging from -60° to +55 °C

The lifespan of the product is 50 years.

With degree of protection up to IP68, it's an optimal solution for marine, offshore & wet environments.

The very high fire withstand >3 hours means that it is perfect for service entrance & risers in civil constructions.

TKL has extreme resistance to chemicals & aggressive atmospheres.

TKL can be easily modified and extended as the facility grows/needs change.

FEATURES OF TKL

Suitable for outdoor & indoor applications;
Ambient temperature from -60° to +55 °C;
Very high degree of protection up to IP68, suitable for marine & wet environments;
High resistance to ultraviolet, chemicals and aggressive environments;
Maintenance free;

High degree of fire withstand;
Small overall dimensions and bending radius;
No phase to phase short circuit possible;
Partial discharge free according to IEC 60137;
Natural (air) cooling;
Very low power losses (I^2R);
Lowest lifecycle costs for end clients.

TECHNICAL SPECIFICATIONS

E-Cu or E-Al conductors are embedded in a cast resin & inert fine particle, composite insulation material.

The compound has excellent dielectric properties together with high mechanical strength.

It is also extremely resistant to corrosive atmospheres.

Modular design of prefabricated elements allows for ease of installation.

The design of the Bus bar joints allows compensation of tolerances, each element can compensate between 10 mm - 20 mm.

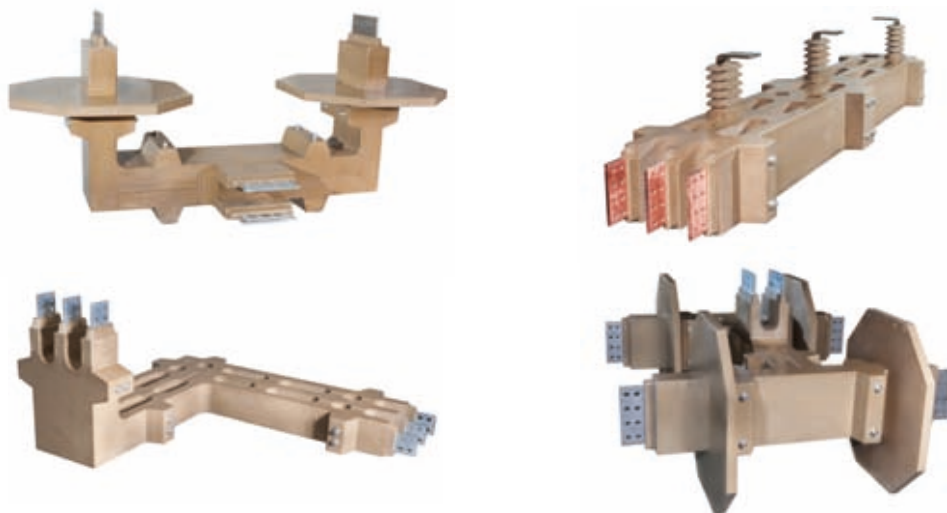

PRODUCTION LINES OF THE BUS BAR

Cast-resin bus bar type TKL is manufactured for low and medium voltage systems.

We use universal casting forms as well as simultaneous automated monitoring, this means we can produce an almost unlimited number of different elements for low and medium voltage systems. We can produce both standard and custom built solutions. The straight elements are made with a maximum length of up to 4 meters.

The shaped elements are manufactured in various configurations: 2-shaped, T-shaped, with bends from 90° to 170°, T-offs, elements with a double bend, custom elements, etc.

THE CAST-RESIN BUS BAR TYPE TKL

Medium voltage systems:

	AC	DC
Nominal voltage	Up to 24 kV	Up to 33 kV
Nominal current	Up to 12 000 A	Up to 18 000 A

TKLN — nominal voltage of up to 1 kV, rated currents up to 7 500 A. Copper or aluminum conductors (from 2 to 10), sealed in one housing made of a special compound. In the same housing a neutral and/ or a protective conductor (section of 50%, 100%, and 150%) can be placed. Bus bars are completed with holders for the bus bar support during the installation on the metal structures. Special assembly supports are provided.

TKLC — rated voltage of up to 24 kV, rated currents up to 12 000 A. The air gaps are designed in to allow for natural cooling of the bus bar. Single or paired conductors can be used in the bus bar design. Bus bars are completed with a self-supporting screen, and holders for the bus bar support during the installation on the metal structures. Special assembly supports are also provided.

Medium voltage system are completed with a special mesh protective screen.
Bus bars for outdoor installation are completed with a climate screen.

Examples of elements:

Low voltage systems:

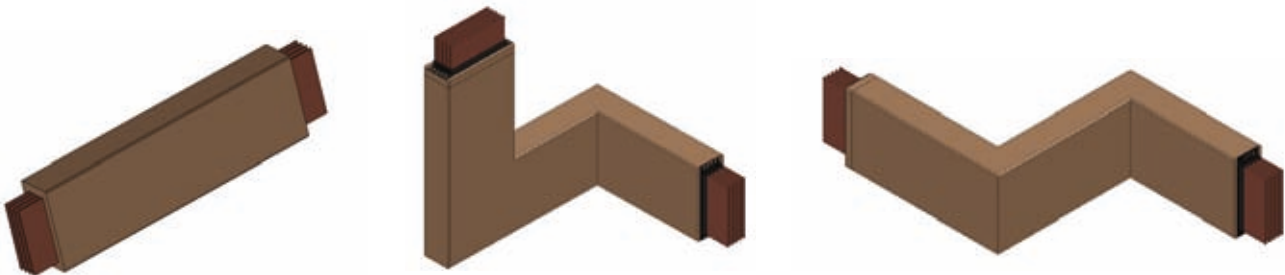

Medium voltage systems:

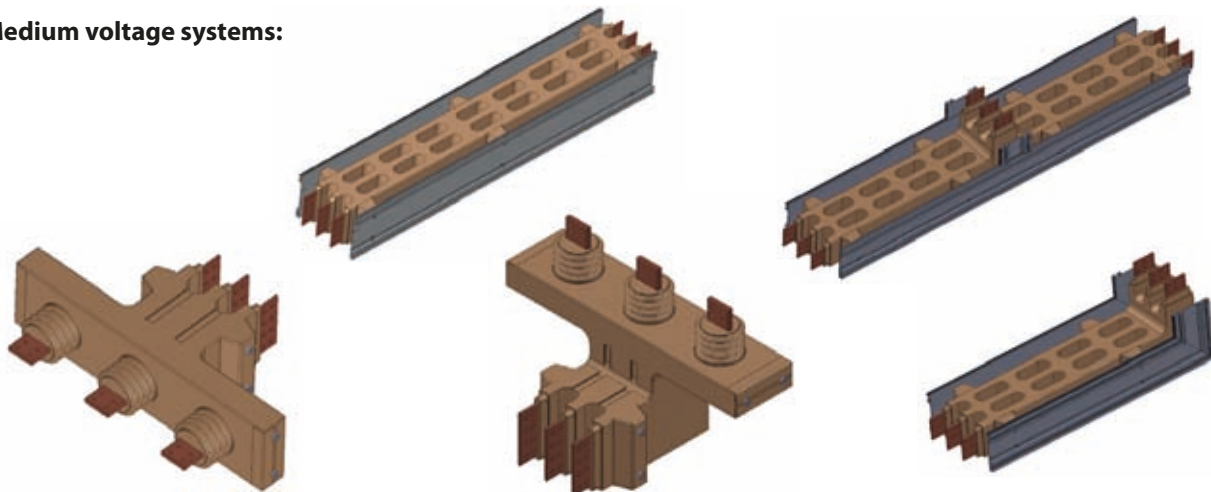

Low voltage systems:

	AC	DC
Nominal voltage	Up to 1 kV	Up to 1.5 kV
Nominal current	Up to 7 500 A	Up to 10 000 A



Protective screen

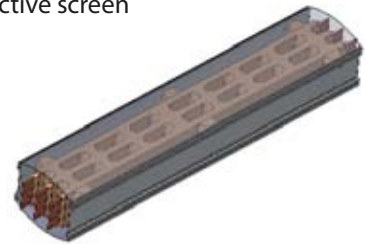

Climate screen

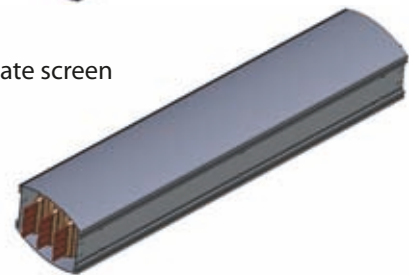

CONNECTION METHODS OF ELEMENTS

The bus bar TKL consists of separate elements. Electrical connections elements sections are carried out by means of copper (aluminum) plates which have embedded nuts. These are tightened by using high-strength steel bolts with the correct torque applied, as defined in the installation manual. After the assembly, the bolted connections are cast with the same compound with which the insulation material of the bus bar's elements is made, thereby providing the insulation continuity through the whole length of the route (3).

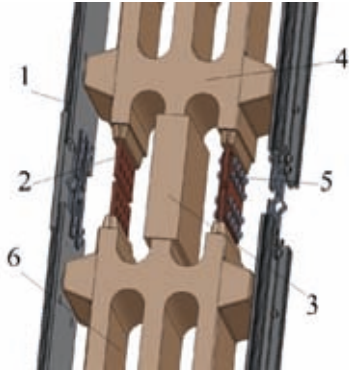

1. Aluminum profile (for mounting of the bus bar and for the screen installation)
2. Aluminum or copper conductor
3. Cast connection
4. TKL bus bar element
5. Bolted connection
6. Air gaps for natural cooling

ELECTRIC CONNECTION METHODS

Considering the variety of TKL element shapes it is possible to connect the cast bus bar to any electric equipment (from the top, side or underneath):

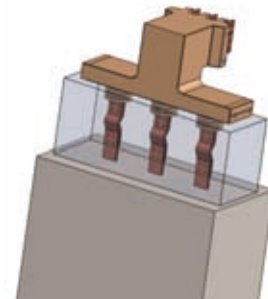

Protective boxes may be used for protection of contact connections (degree of protection IP65 and greater). For the connection of the TKL bus bar to other electric equipment, bus flexible connectors of various designs are used:

Press-welded flexibles;



High-flexible braids



To compensate the linear changes caused by thermal expansion/contraction, a special expansion element is supplied to be installed through each 35-40 m of a direct route.

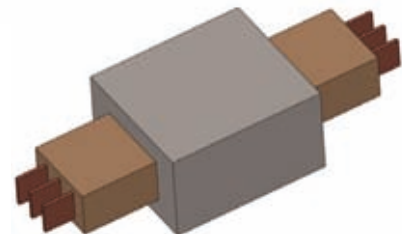

ADDITIONAL EQUIPMENT AND ACCESSORIES

Depending on the specification requirements, cast resin bus bar TKL can be completed with an additional electric equipment:

1. Current transformers
2. Voltage transformers
3. Disconnecting switches
4. Tap off boxes with MCCB
5. Terminal elements for the cable connection
6. Overvoltage limiters
7. Automatic circuit breakers
8. Tap-offs for other rated currents

THE CAST-RESIN BUS BAR TYPE TKL

TYPE TESTS

In addition to in house routine testing our products have undergone rigorous type testing as follows:

- Heat tests;
- Tests for stability under continuous currents of a short-circuit;
- Tests for resistance to mechanical factors of the environment;
- Tests for mechanical stability;
- Water-proof and dust-proof tests;
- Tests for heat resistance and frost resistance during the operation, transportation and storage;
- Tests of the electric strength of insulation;
- Test for the intensity of partial discharges;
- Seismic stability tests and other tests.

INSTALLATION METHODS

Cast-resin bus bar type TKL can be installed in the following variations, ceiling , floor, wall, both horizontal & vertical.

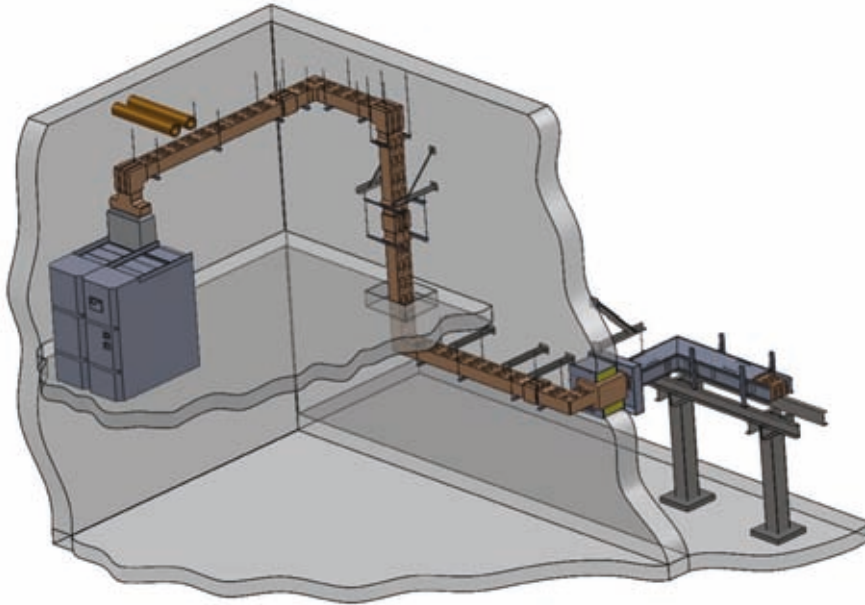

THE STANDARD SET OF EQUIPMENT

HARDWARE includes:

- Cast-resin bus bar type TKL elements;
- Connection plates;
- Molds for casting the elements connection places during the installation;
- Fixation system;
- Chemical components for compound preparation (during the installation);
- Flexible connectors;
- Earthing cable;
- Factory packaging (wooden pallets/boxes).

Additional options:

- A vacuum mixer with the drive (for medium voltage);
- Protective boxes;
- Accessories/additional equipment.

SOFTWARE includes:

- Packing list;
- The set of assembly factory drawings;
- Installation instruction manual;
- Test reports for each element;
- Technical passport.

The set of associated documentation is provided in English.

PACKING

According to the design documentation bus bars & components are packed and fastened into wooden boxes. Separately delivered small size assembly units, details and fasteners are packed into wooden boxes according to the design documentation.

QUALITY ASSURANCE AND CERTIFICATION OF CAST-RESIN BUS BAR TYPE TKL AND SOLID INSULATED BUS BAR TYPE TPL

Certificates issued for TKL & TPL meet the requirements of ISO 9001:2008

TPL & TKL quality is ensured by means of close final inspection of electrical equipment.

All conductor materials (copper and aluminum pipes, rods and stripes), insulation materials, nylon clamps and components from sub suppliers are rigorously checked.

We also monitor each step of the electrical pathway during production.

Each TPL & TKL element is then high voltage tested in the manufacturer's laboratory.

Netherlands KEMA laboratory certified TPL & TKL.



FIRE SAFETY

TPL & TKL are made of self-extinguishing materials. Both products have a very high fire withstand.

The corresponding test reports and fire certificates are issued for them. Wall penetrations are fire safe. Openings, through which a current distributor runs, are filled with special noncombustible materials.

OUR CORE BUSINESS

- We help you choose the optimal TPL /TKL solution for your project;
- We engineer the TPL & TKL components & fixing systems;
- We produce test & deliver hardware & software;
- Supervision/training or turnkey installation of your TPL /TKL distribution system.

**RTC-ELECTRO-M PROVIDING FIT AND FORGET SOLUTIONS
TO ENABLE LOWEST LIFECYCLE COSTS**

Questionnaire

Project name/location _____ / _____

Line no./lines total _____ / _____

Approximate purchase date _____

Type of bus bars*	Nominal current, A	Nominal voltage, kV	Conductor material	Enclosure
<input type="checkbox"/> TPL <input type="checkbox"/> TKL	—	—	<input type="checkbox"/> copper <input type="checkbox"/> aluminum	<input type="checkbox"/> indoor <input type="checkbox"/> outdoor
Frequency, Hz	Delivery terms	Currency	Length	
<input type="checkbox"/> 0 Hz (DC) <input type="checkbox"/> 50 Hz (AC) <input type="checkbox"/> _____	<input type="checkbox"/> FCA Pavlovskii Posad <input type="checkbox"/> DPP _____ <input type="checkbox"/> _____	<input type="checkbox"/> \$ <input type="checkbox"/> € <input type="checkbox"/> RUR	1. Length of the line, meter 2. Bends per line, piece ** 3. Terminal elements, pc ***	_____ _____ _____
Additional information (If you don't fill it in we will use the standard options)				
Ambient temperature, °C	Thermal short circuit current (3 sec), kA	Dynamic short circuit current, kA	Connected equipment (left side/right side)	Number of conductors (for low voltage)
<input type="checkbox"/> minimum <input type="checkbox"/> maximum	_____ for 3 sec OR _____ for 1 sec	—	switchgear: <input type="checkbox"/> / <input type="checkbox"/> SF6 connection OR <input type="checkbox"/> / <input type="checkbox"/> Standard connection <input type="checkbox"/> / <input type="checkbox"/> transformer <input type="checkbox"/> / <input type="checkbox"/> reactor <input type="checkbox"/> / <input type="checkbox"/> generator circuit breaker _____ / _____	<input type="checkbox"/> 2 phases (DC) <input type="checkbox"/> 3 phases only <input type="checkbox"/> 3 phases and earth conductor (4 wires) <input type="checkbox"/> 3 phases and earth conductor and neutral conductor (5 wires) <input type="checkbox"/> _____
Degree of protection	Installation methods	Altitude, m		
<input type="checkbox"/> IP54 <input type="checkbox"/> IP65 <input type="checkbox"/> IP67 <input type="checkbox"/> IP68 <input type="checkbox"/> _____	<input type="checkbox"/> to the overpass <input type="checkbox"/> to the wall <input type="checkbox"/> to the floor <input type="checkbox"/> to the ceiling <input type="checkbox"/> _____	—		
Additional information****				

* Please leave empty if you want us to make a choice ourselves

** If there is no information we take into consideration 1 bend per each 5 meter of bus bar route

*** If there is no information we take into consideration 2 terminal elements to connect the both line sides to electrical equipment (like transformer, reactor etc.)

**** Please note the necessity of some extra items: tap-offs, current or voltage transformers, overvoltage limiters, metal boxes for protection bus bar to equipment connections and so on.



Sales Department:
007-812-340-01-55, ext. 214

www.rtc-electro-m.ru
info@rtc-electro-m.com